

SlipStream

From The Motion Minds at LM76



- **Stock Lengths up to 3 Meters**
 - **Multiple Axis System Design**
 - **Custom Lengths up to 6 Meters**
 - **All Steel Profile Rail for High Load Capacity**
 - **50 mm Wide Steel Reinforced Belt for Heavy Loads**
 - **Stepper & Servo Options Available**
 - **Rugged Design**
- 3D CAD Models Available Upon Request**
Complete Systems
Shipping in 2 weeks or less ARO
- **T-slots on three sides for mounting and accessories**

1
•
8
0
•
5
1
3
•
3
1
6
3

www.LM76.com

Single Carriage Weight: 1.7lbs (0.75kg) Dual Carriage Weight: 3.1lbs. (1.40kg)

Weight without Motor: 7.59kg/meter

Pitch Diameter of Pulley: 44.6mm

Pully Mass Moment of Inertia: 0.0001393 kg x meter/sq $1.39 \times 10^{-4} \text{ kg/m}^2$

Effective Pulley Circumference: 140mm

Max Dynamic Load per Carriage: 22.3 KN

Rail/Carriage Coefficient of Friction: 0.003

Belt Style: 5mm HTD, 50mm Wide

Belt Material: Steel Reinforced Polyurethane

Belt Thickness: 3.6mm

Max Belt Strength @ 3000rpm: 1300N

Tooth height: 2.1mm

Accuracy: 0.2mm/300m

Accuracy: 0.2mm/300mm

Repeatability: 0.1mm

Breakaway Torque: <.33 Nm (in-lbs.) NOTE: Maximum Speed of 5 m/s is the mechanical limit

NOTE: Actual Max Speed is based on motor and drive package.

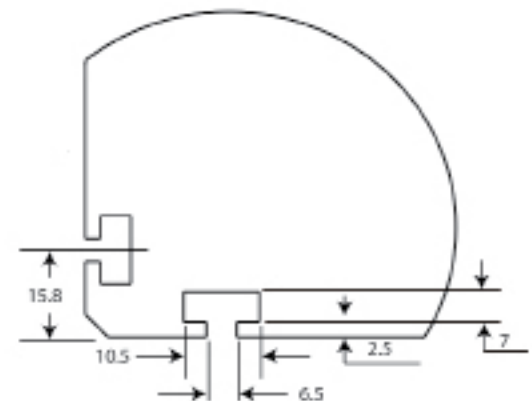
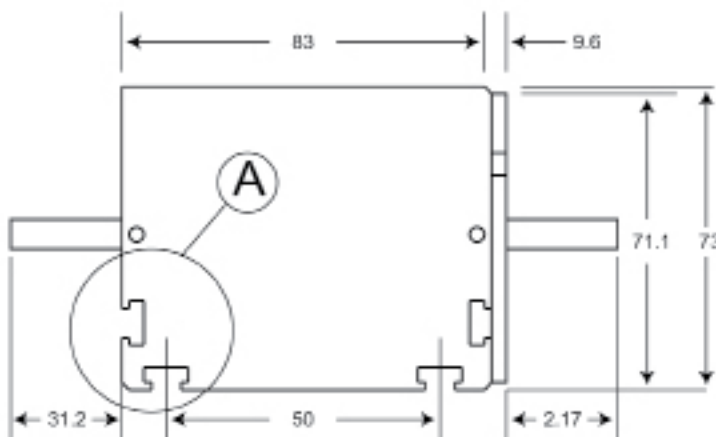
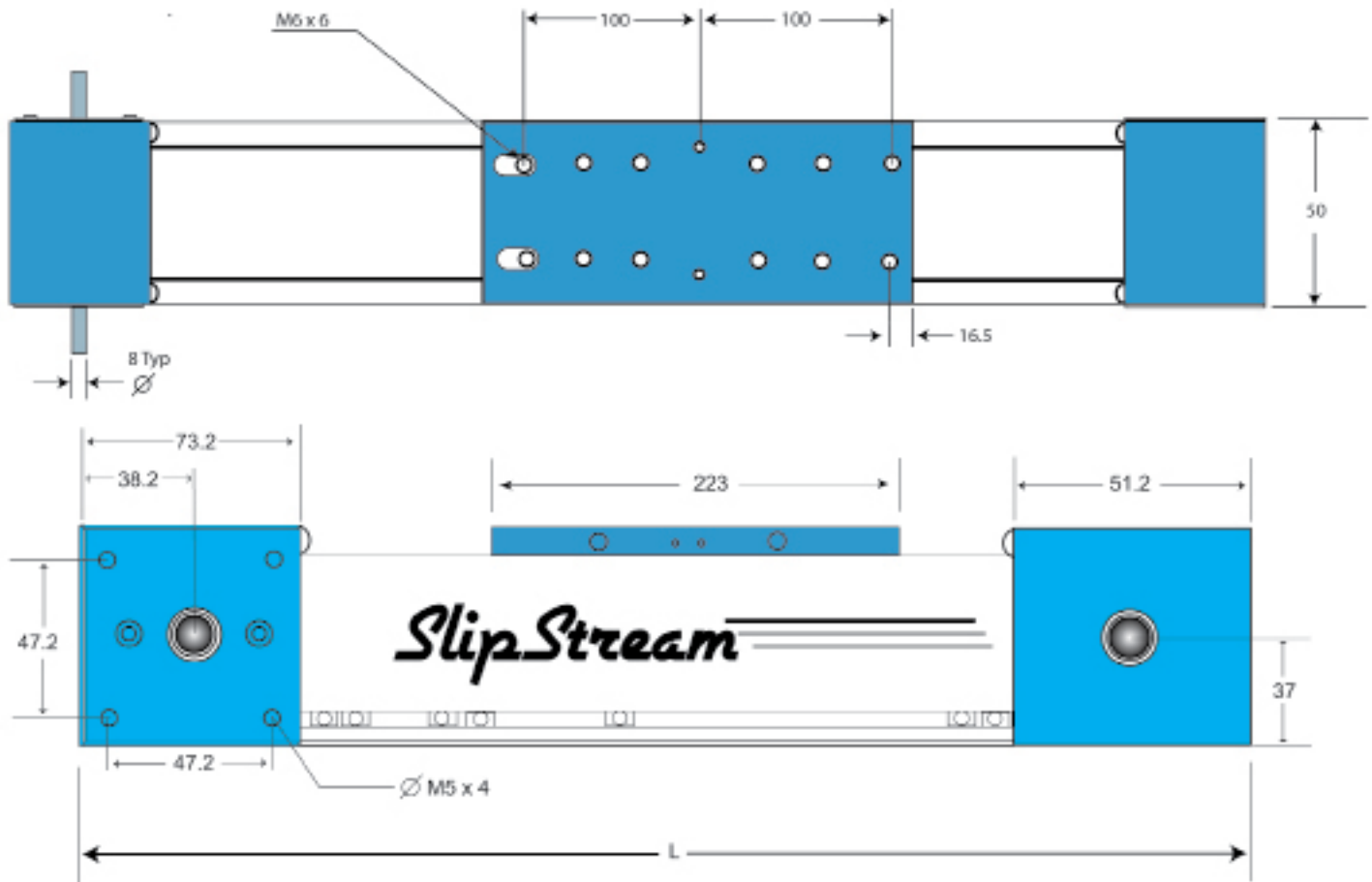
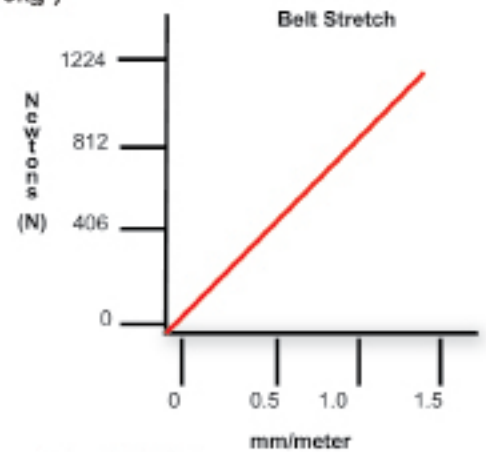

www.LM76.com

LM76 Linear Motion Bearings & Slides
140 Industrial Drive
E. Longmeadow, Ma 01028